

1. MECHANIC DIMENSIONS

1.1 Dimensions

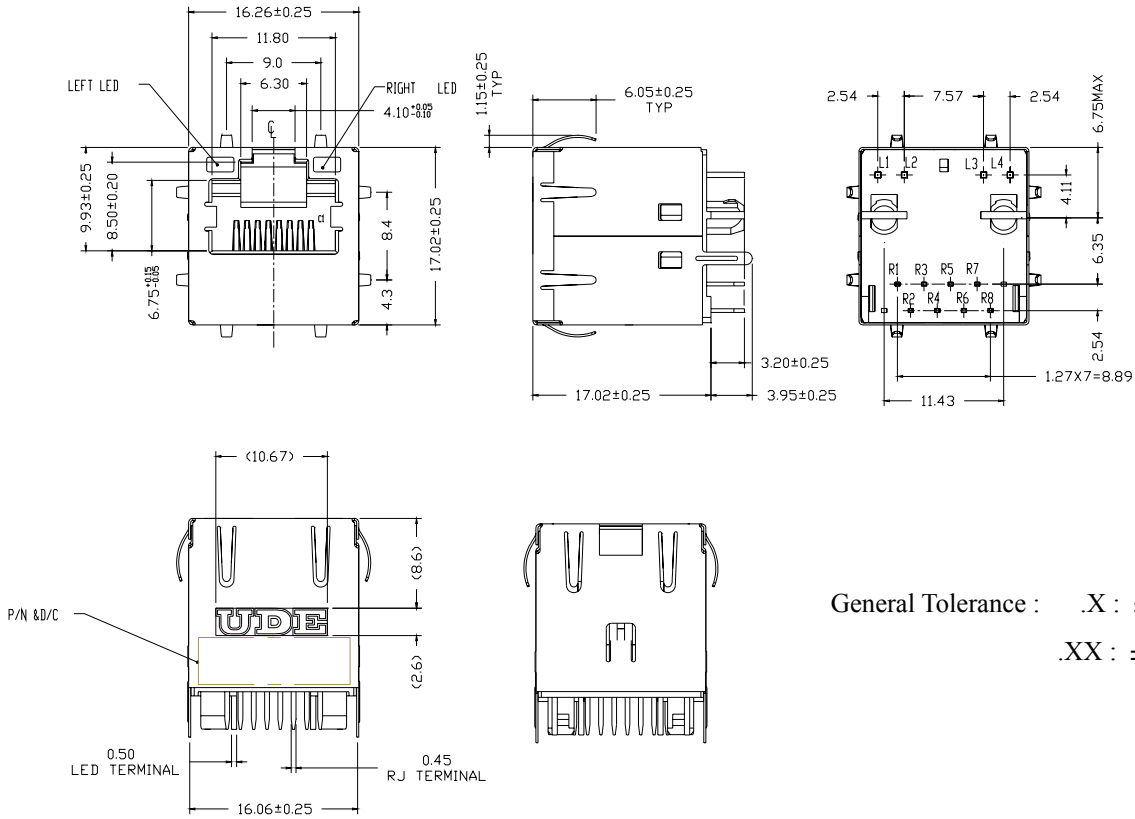

General Tolerance : .X : ±0.25
 .XX : ±0.13

1.2 PCB Layout

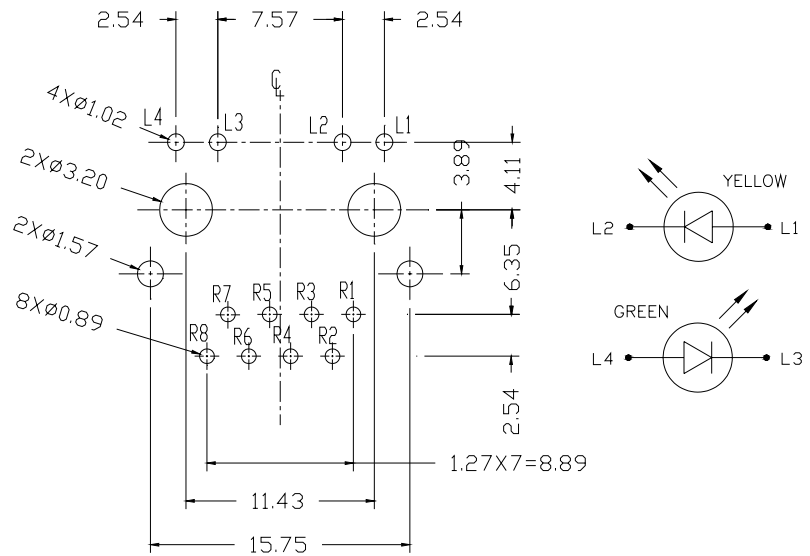

Recommended PCB layout
 component side view
 PCB thickness : 1.6mm
 The tolerance are ±0.05mm

1.3 RJ PLUG SPECIFICATION

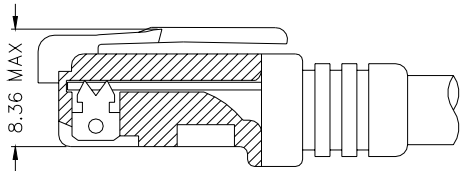
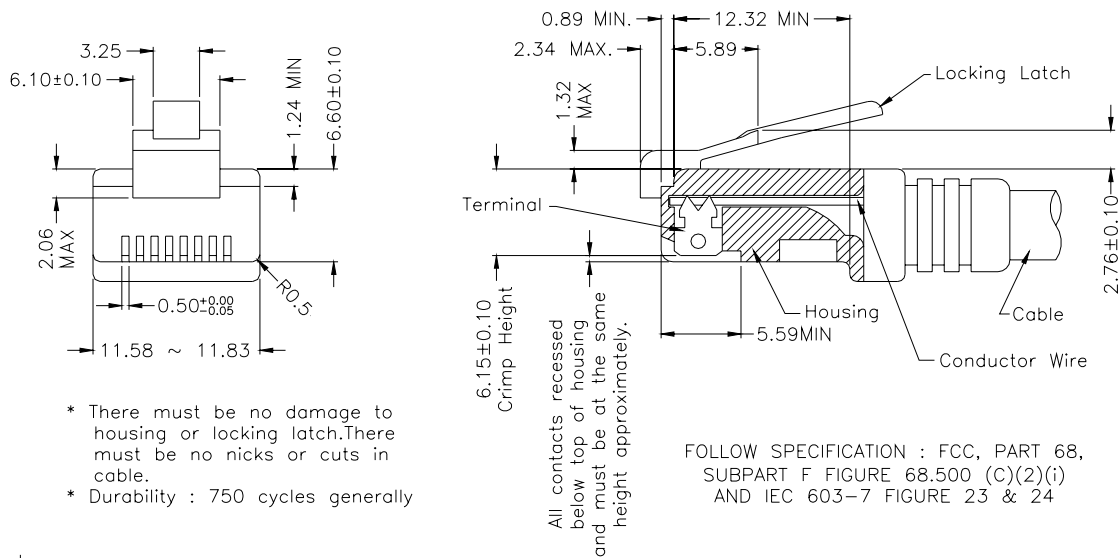

FOLLOW SPECIFICATION : FCC, PART 68, SUBPART F, FIGURE 68.500 (C)(2)(ii)

STANDARD MODULAR PLUG ASSEMBLY

2. REQUIREMENTS

2.1. Design and Construction

Product shall be of design, construction and physical dimensions specified on applicable

2.2. Materials

2.2.1. Terminal Parts :

2.2.1.1. RJ Terminal : Phosphor Bronze , Thickness=0.30mm

Finish : (a) Contact Area : Gold Flash

(b) Solder tail Area : 100μ” min. Tin

(c) Underplating : 50~100μ” Nickel over all

2.2.1.2. Input Terminal : Brass , Thickness=0.35mm

Finish : 100μ” min. Tin over 50~100μ” min. Nickel

2.2.1.3. Link Terminal : Brass , Thickness=0.25mm

Finish : 100μ” min. Tin over 50~100μ” min. Nickel

2.2.2. Plastic Parts :

2.2.2.1. Housing : Thermoplastic , PA , Black

UL FILE No. : E47960

Grade : TE250F6

SPEC NO. :		REV. : XA	ECN NO. :		PAGE :	2 / 6
------------	--	-----------	-----------	--	--------	-------

Flame Class : UL94 V-0

2.2.2.2. Coil Case : Thermoplastic , PA , Black

UL FILE No. : E47960

Grade : TE250F6

Flame Class : UL94 V-0

2.2.3. Shell Parts :

2.2.3.1. Front Shell : Stainless, Thickness=0.20mm

2.2.3.2. Back Shell : Stainless, Thickness=0.20mm

Grounding Leg : Pre-soldering

2.3. Operating and Storage Temperature

2.3.1. Operating Temperature : 0 TO +70

2.3.2. Storage Temperature : -40 TO +85

2.4. RJ45 specifications:

2.4.1. Insulation Resistance: 500MΩMin

2.4.2. Dielectric Withstanding Voltage: 1000VAC Min

2.5. Performance and Test Description

Product is designed to meet electrical, mechanical and environmental performance requirements specified in below table. All tests are performed at ambient environmental conditions per MIL-STD-1344A and EIA-364 unless otherwise specified.

2.6. Packaging and Packing

All parts shall be packaged and packed to protect against physical damage, corrosion and deterioration during shipment and storage.

3. ELECTRICAL CHARACTERISTICS

3.1. Schematic

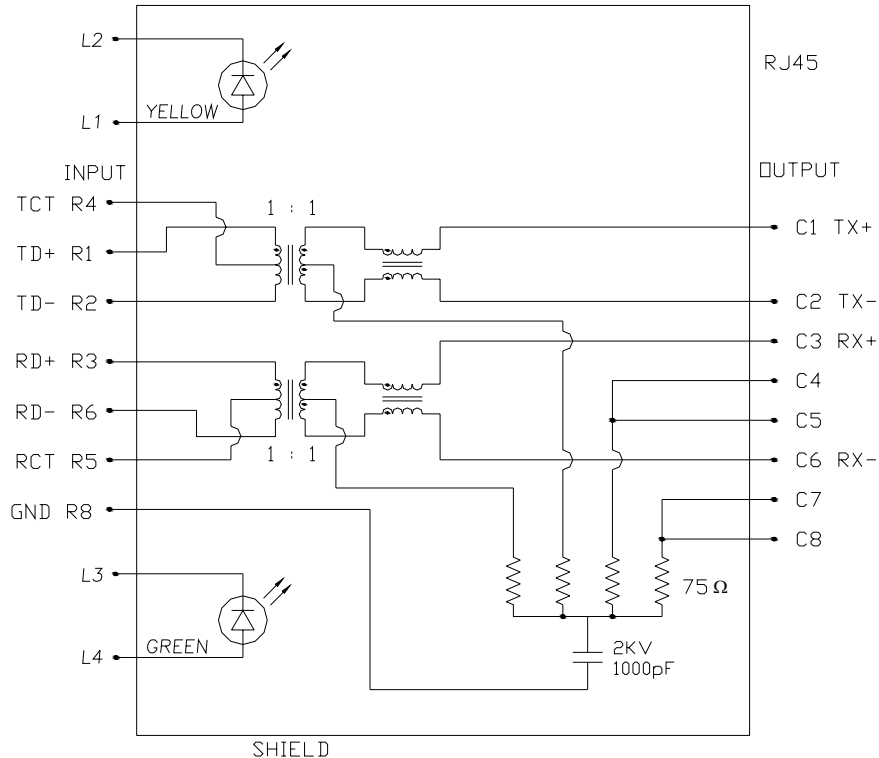

3.2. Transmitter filter & Receiver filter

Type : Balance low pass 100Ω impedance

Insertion loss : 1~100 MHz -1.0dB MAX.

Return loss : 1~30 MHz -18dB MIN. load 100Ω

30~60 MHz -16dB MIN. load 100Ω

60~80 MHz -12dB MIN. load 100Ω

3.3. Common Mode Rejection

@ 1~100 MHz -30dB MIN.

3.4. Cross Talk

@ 1~100 MHz -30dB MIN

3.5. INDUCTANCE @ 100KHz, 0.1V, 8mA DC BIAS

Input(R1-R2), Input(R3-R6) : 350μH MIN.

3.6. HiPot TEST

Input(R1-R2) to Output(C1-C2) : 1500VAC, 60sec

Input(R3-R6) to Output(C3-C6) : 1500VAC, 60sec

4. ORDER INFORMATION

MR V 1 - 1 X X 0 XXX X
A B C D

A: LED Code

	Left LED		Right LED	
	-L3/+L4	+L3/-L4	-L1/+L2	+L1/-L2
0	w/o	w/o	w/o	w/o
1	Green		Yellow	
2		Green		Yellow
3	Green		Green	Yellow
4	Yellow		Green	
5		Green	Yellow	Green
6	Green	Orange	Yellow	
7	Yellow		Green	Orange
8	Yellow		Orange	Green
9	Green	Orange	Green	
D	Green			Yellow

B : Spring & Logo Code

SPRING \ LOGO	W/o All	W/All
W/O	A	B
W/	0	1

C : Schematic type

8K1 : 8K1 Circuit

D : Plating Code

RJ terminal contact area

A: gold flash

Dipping temperature profile

(Note)The measuring point for the specified temperature shall be on the soldered part of the leads

