

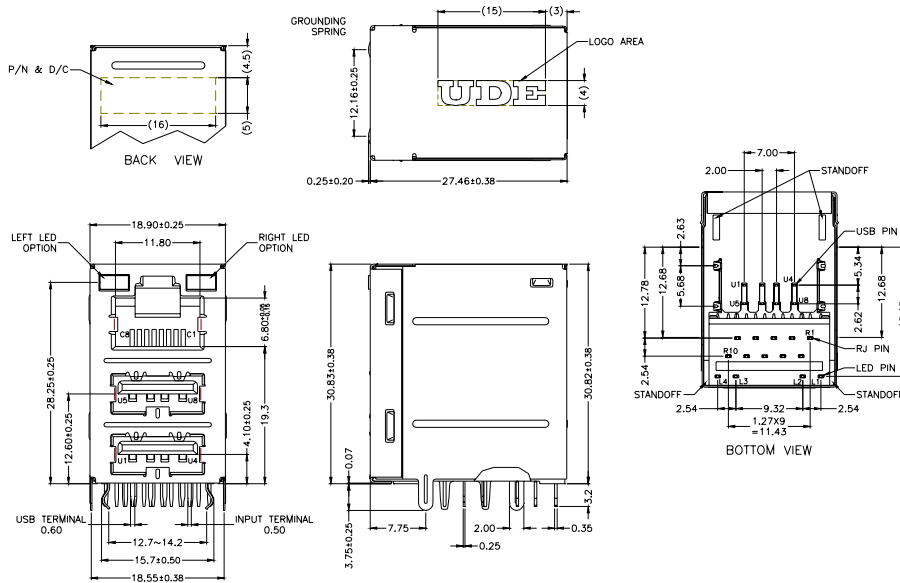

# 1 MECHANIC DIMENSIONS

## 1.1 Dimensions



General Tolerance : .X     :±0.25  
 .XX    :±0.13

## 1.2 PCBLayout

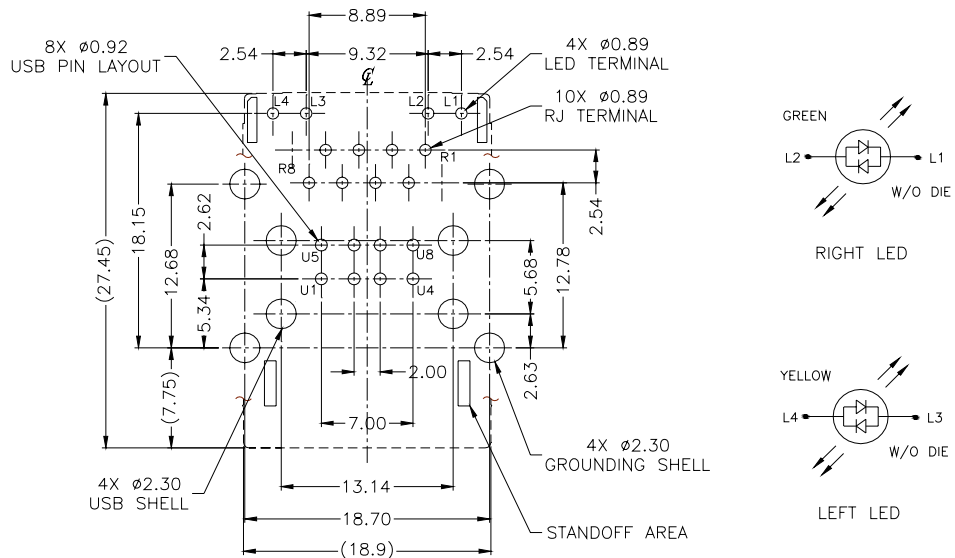

RECOMMENDED PCB LAYOUT(8P10C)  
 COMPONENT SIDE PCB THICKNESS : 1.60mm  
 ALL DIMENSION TOLERANCE ARE ±0.05 UNLESS OTHERWISE SPECIFIED

### 1.3 RJ PLUG SPECIFICATION

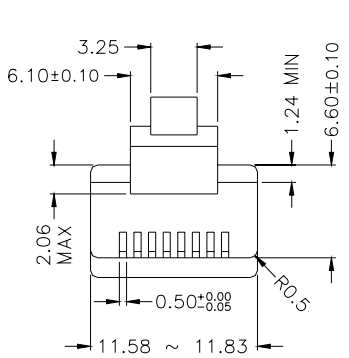

- \* There must be no damage to housing or locking latch. There must be no nicks or cuts in cable.
- \* Durability : 750 cycles generally

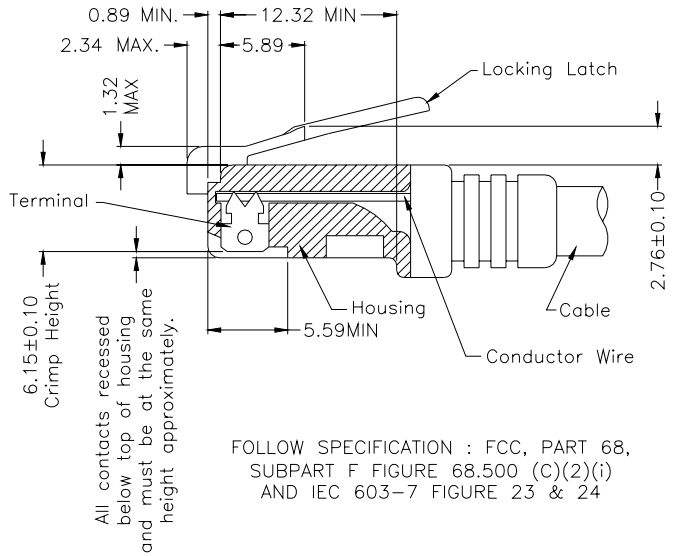

FOLLOW SPECIFICATION : FCC, PART 68, SUBPART F FIGURE 68.500 (C)(2)(i) AND IEC 603-7 FIGURE 23 & 24

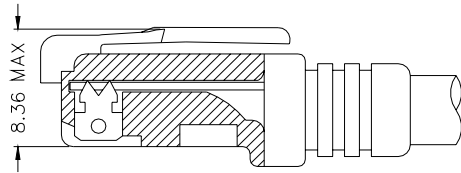

STANDARD MODULAR PLUG ASSEMBLY

FOLLOW SPECIFICATION : FCC, PART 68, SUBPART F FIGURE 68.500 (C)(2)(ii)

### 1.4 USB PLUG SPECIFICATION

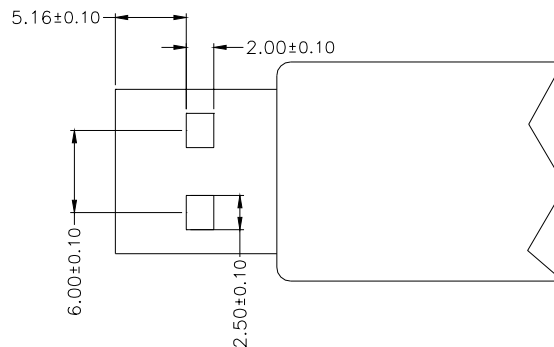
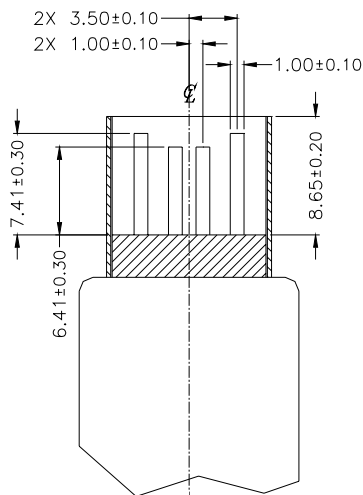
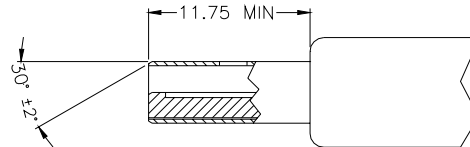
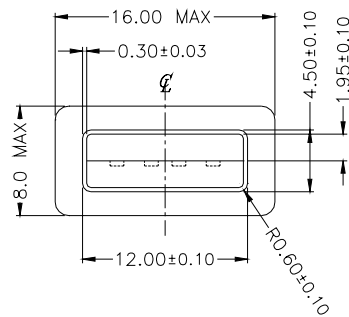

FOLLOW SPECIFICATION : Universal Series Bus Figure 6-9. USB Series A Plug Interface Drawing

## 2 REQUIREMENTS

### 2.1 Materials

#### 2.1.1 Terminal Parts :

2.1.1.1 RJ Output Terminal : Phosphor Bronze , Thickness=0.30mm

Finish : ( a ) Contact Area : 30 $\mu$  " min. Gold

( b ) Solder tail Area : 100 $\mu$  " min. Tin

( c ) Underplating : 50~100 $\mu$  " Nickel over all

2.1.1.2 USB Terminal : Phosphor Bronze , Thickness=0.25mm

Finish : ( a ) Contact Area : 30 $\mu$  " min. Gold

( b ) Solder tail Area : 100 $\mu$  " min. Tin

( c ) Underplating : 50~100 $\mu$  " Nickel over all

2.1.1.3 RJ Input Terminal : Brass , Thickness=0.35mm

Finish : 100 $\mu$  " min. Tin over 50~100 $\mu$  " min. Nickel

2.1.1.4 LED Terminal : Brass , Thickness=0.35mm

Finish : 100 $\mu$  " min. Tin over 50~100 $\mu$  " min. Nickel

#### 2.1.2 Plastic Parts :

2.1.2.1 Housing : Thermoplastic , PBT , Black

UL FILE No. : E130155

Manufacturer : Nan Ya Plastic Corp.

Grade : 1410

Flame Class : UL94 V-0

2.1.2.2 Spacer : Thermoplastic , PBT , Black

UL FILE No. : E130155

Manufacturer : Nan Ya Plastic Corp

Grade : 1410

Flame Class : UL94 V-0

#### 2.1.3 Shell Parts :

2.1.3.1 Front Shell : Stainless, Thickness=0.25mm

2.1.3.2 Back Shell : Stainless, Thickness=0.20mm

Grounding Leg : Pre-soldering , Sn/Ag/Cu( 96.5 / 3 / 0.5 )

2.1.3.3 Grounding Leg of USB : Brass , Thickness=0.25mm

Finish : 100 $\mu$  " min. Bright Tin over 50~100 $\mu$  " min. Nickel

#### 2.1.4 LED Lamp

2.1.4.1 Lens Color : color diffused

2.1.4.2 Emitted Color : Green , Yellow , Orange

2.1.4.3 Wave Length : Green 568nm ; Yellow 585nm ; Orange 610nm

SPEC NO. :		R E V . :	ECN NO. :		PAGE :	3 / 6
------------	--	-----------	-----------	--	--------	-------

2.1.4.4 Power Dissipation: 100mW Max

2.1.4.5 Forward Current : 30mA Max

2.1.4.6 Forward Voltage: 2.2 V Typical

2.1.4.7 Reverse current: 100 uA Max @ 5 V

2.2 Operating and Storage Temperature

2.2.1 Operating Temperature : 0 TO +70

2.2.2 Storage Temperature : -40 TO +85

2.3 RJ45 specifications:

2.3.1 Insulation Resistance: 500M ohm Min

2.3.2 Dielectric Withstanding Voltage: 1000VAC Min

2.4 USB specifications:

2.4.1 Contact Current Rating: 1.5 A Max

2.4.2 Contact Resistance: 30m ohm Max

2.4.3 Insulation Resistance: 1000M ohm Min

2.4.4 Dielectric Withstanding Voltage: 500VAC Min

3 ORDER INFORMATION

R U 1 - 1 X X X XXX X  
 A B C D E

A : LED Code

	left LED		right LED	
	-L3/+L4	+L3/-L4	-L1/+L2	+L1/-L2
0 :	w/o	w/o	w/o	w/o
1 :	Green		Yellow	
2 :		Green		Yellow
3 :	Green		Green	Yellow
4 :	Yellow		Green	
5 :		Green	Yellow	Green
6 :	Green	Orange	Yellow	
7 :	Yellow		Green	Orange
8 :	Yellow		Orange	Green

B : Spring & Logo Code

		Spring				
		w/o	T/S/B	T/S	Top	S
Logo	w/o	0	-	-	-	-
	w	1	-	-	-	-

C : GP code

1: w/Lead

A: Green product

D : Schematic type

000 : W/O Xmer

E : Plating Code

RJ terminal contact area

USB terminal contact area

F: 30u”Au or 10u”Pd/Ni +10u”Au

30u”Au or 10u”Pd/Ni +10u”Au

Dipping temperature profile

(Note)The measuring point for the specified temperature shall be on the soldered part of the leads

