

1. MECHANIC DIMENSIONS

1.1 Dimensions

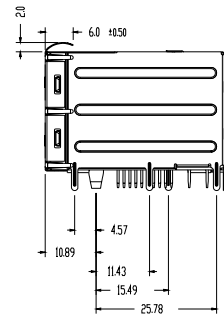
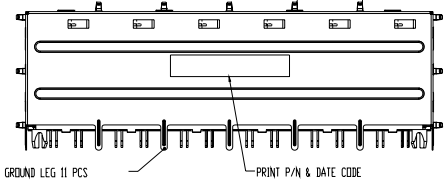
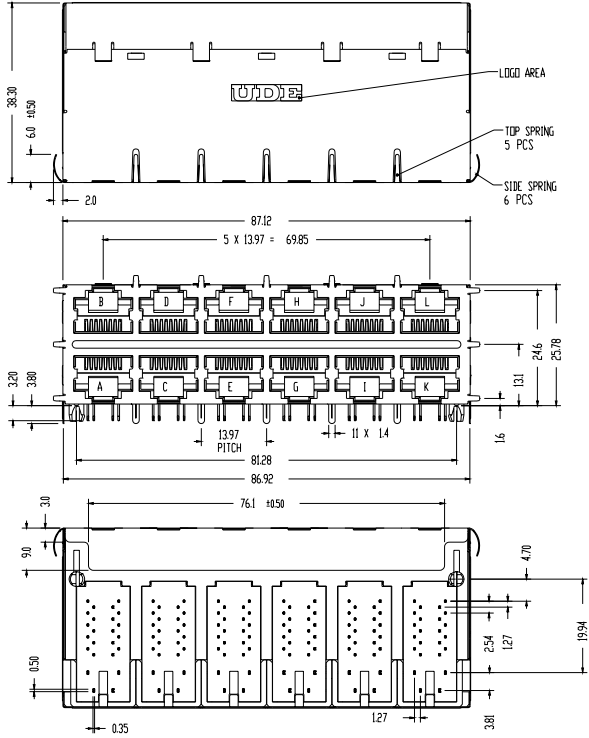

General Tolerance : .X : ±0.25
 .XX : ±0.13

1.2 PCB Layout

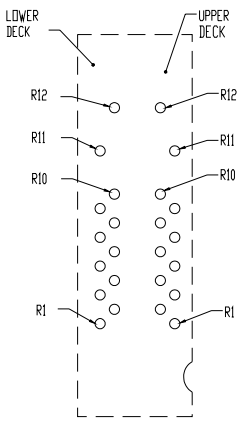
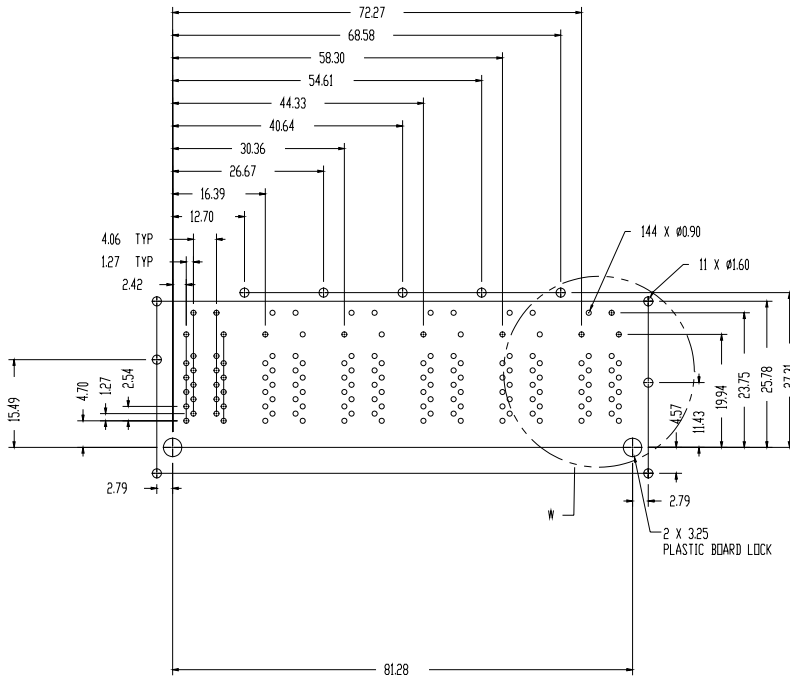

RECOMMENDED PCB LAYOUT
 ALL DIMENSION TOLERANCE ARE
 COMPONENT SIDE
 ± 0.05 UNLESS OTHERWISE SPECIFIED

1.3 RJ PLUG SPECIFICATION

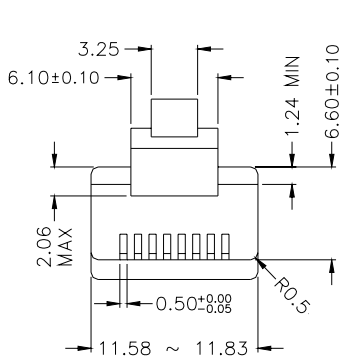

- * There must be no damage to housing or locking latch. There must be no nicks or cuts in cable.
- * Durability : 750 cycles generally

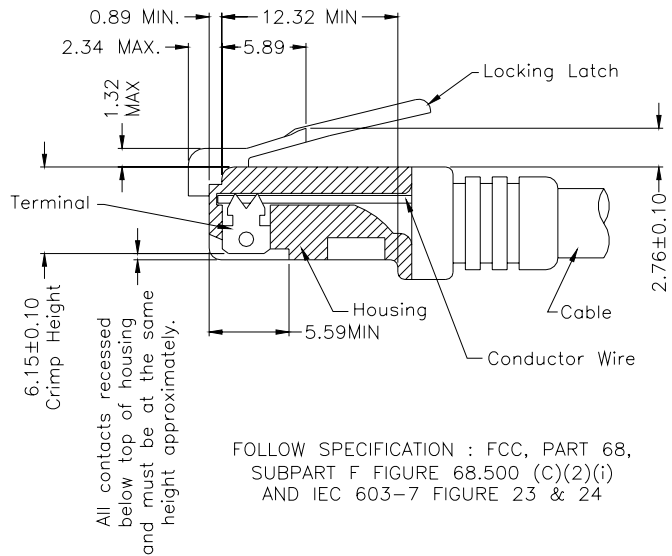

FOLLOW SPECIFICATION : FCC, PART 68, SUBPART F FIGURE 68.500 (C)(2)(i) AND IEC 603-7 FIGURE 23 & 24

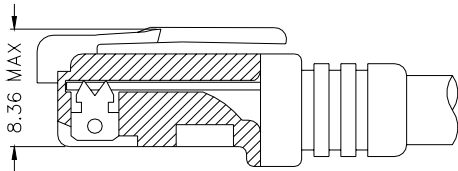

FOLLOW SPECIFICATION : FCC, PART 68, SUBPART F FIGURE 68.500 (C)(2)(ii)

STANDARD MODULAR PLUG ASSEMBLY

2. REQUIREMENTS

2.1 Materials

2.1.1 Terminal Parts :

2.1.1.1 RJ Output Terminal : Phosphor Bronze , Thickness=0.30mm

Finish : (a) Contact Area : 30μ” Gold

(b) Solder tail Area : 100μ” min. Tin

(c) Underplating : 50~100μ” Nickel over all

2.1.1.2 RJ Input Terminal : Brass , Thickness=0.35mm

Finish : 100μ” min. Tin over 50~100μ” min. Nickel

2.1.1.3 Case Terminal : Brass , Thickness=0.35mm

Finish : 100μ” min. Tin over 50~100μ” min. Nickel

2.1.1.4 Link Terminal : Brass, Thickness=0.20mm

Finish: 100”u min. Tin over 50~100μ” min. Nickel

2.1.1.5 LED Terminal : Brass, Thickness=0.35mm

Finish : Tin over 50~100μ” min. Nickel

2.1.2 Plastic Parts :

2.1.2.1 Housing : Thermoplastic , PBT , Black

UL FILE No. : E59481

Grade : PBT-4830

Flame Class : UL94 V-0

SPEC NO. :		REV. : XA	ECN NO. :		PAGE :	2 / 6
------------	--	-----------	-----------	--	--------	-------

2.1.2.2 Spacer : Thermoplastic , PBT , Black

UL FILE No. : E59481

Manufacturer :. Chang Chun Plastics Co Ltd

Grade : PBT-4830

Flame Class : UL94 V-0

2.1.2.3 Case : Thermoplastic , PA , Black

UL FILE No. : E119177

Manufacturer :. DSM Engineering Plastics B V

Grade : TE250F6

Flame Class : UL94 V-0

2.1.2.4 Link Spacer : Thermoplastic , PBT , Black

UL FILE No. : E59481

2.1.2.5 Cover : Thermoplastic , PBT , Black

UL FILE No. : E59481

2.1.2.6 LED Insert : Thermoplastic PC Transparent

UL FILE No. : E45587

2.1.3 Shell Parts :

2.1.3.1 Front Shell : Stainless, Thickness=0.20mm

2.1.3.2 Back Shell : Stainless, Thickness=0.20mm

Grounding Leg : Pre-soldering

2.2 Operating and Storage Temperature

2.2.1 Operating Temperature : 0 TO +70

2.2.2 Storage Temperature : -40 TO +85

2.3 RJ45 specifications:

2.3.1 Insulation Resistance: 500M ohm Min

2.3.2 Dielectric Withstanding Voltage: 1000VAC Min

3 ELECTRICAL CHARACTERISTICS

3.1 Schematic

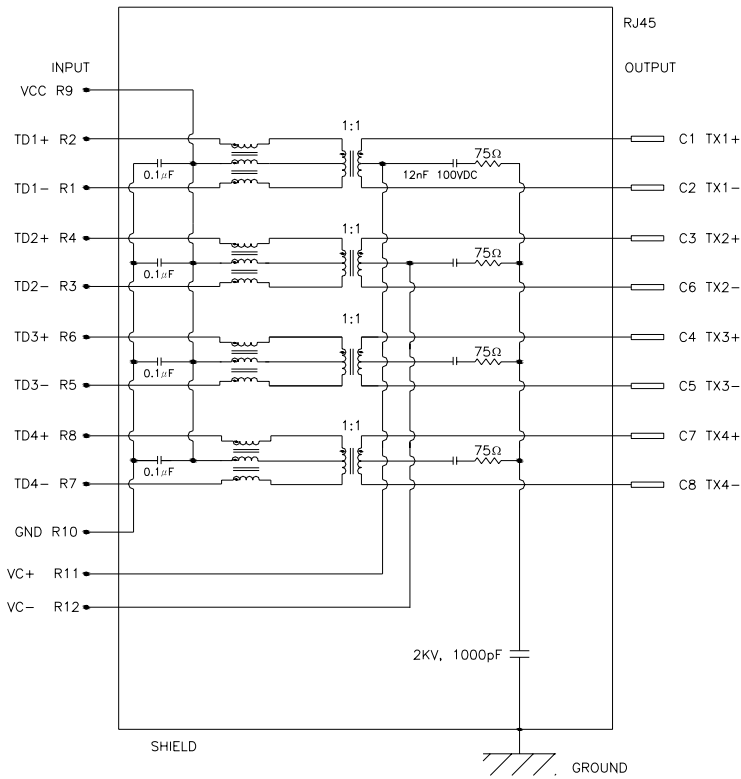

3.2 Transmitter filter & Receiver filter

Type : Balance low pass 100Ω impedance

Insertion loss : 1~100 MHz -1.0dB MAX.

Return loss : 1~30 MHz -18dB MIN. load 100Ω
 30~60 MHz -16dB MIN. load 100Ω
 60~80 MHz -12dB MIN. load 100Ω
 80~100 MHz -10dB MIN. load 100Ω

3.3 Common Mode Rejection

@ 1~100 MHz -30dB MIN.

3.4 Cross Talk

@ 1~100 MHz -30dB MIN

3.5 INDUCTANCE @ 100KHz, 0.1V, 8mA DC BIAS

Input(R2-R1), Input(R4-R3), Input(R6-R5), Input(R8-R7) : 350µH MIN

3.6 HiPot TEST

Input(R2-R1) to Output(C1-C2) : 2250VDC, 60sec

Input(R4-R3) to Output(C3-C6) : 2250VDC, 60sec

Input(R6-R5) to Output(C4-C5) : 2250VDC, 60sec

Input(R8-R7) to Output(C7-C8) : 2250VDC, 60sec

SPEC NO. :		REV. : XA	ECN NO. :		PAGE :	4 / 6
------------	--	-----------	-----------	--	--------	-------

4. ORDER INFORMATION

R N 6 - 1 X X 0 XXX X
A B C D

A: LED Code

	Left LED		Right LED	
	-L3/+L4	+L3/-L4	-L1/+L2	+L1/-L2
0	w/o	w/o	w/o	w/o
1	Green		Yellow	
2		Green		Yellow
3	Green		Green	Yellow
4	Yellow		Green	
5		Green	Yellow	Green
6	Green	Orange	Yellow	
7	Yellow		Green	Orange
8	Yellow		Orange	Green
9	Green	Orange	Green	

B : Spring & Logo Code

	W/ SPRING	W/O SPRING	W/ Top & Bottom	W/ Top & Side
W/ Logo	1	2	3	4

C : Schematic type

F51 : F51 Circuit

D : Plating Code

RJ terminal contact area

F: 30u”Au or 10u”Pd/Ni +10u”Au

Dipping temperature profile

(Note) The measuring point for the specified temperature shall be on the soldered part of the leads

