

American Thermal Products

Model : MBA49002 Series

BGA Heat Sink Specification

For North Bridge Chip set



1. Material : Al 6063
2. Dimension :
 Foot print : 37.5x37.5mm
 Height : 12,15,18,21,23,28,33 mm
 Base (thickness) : 2.6mm
3. Finish: Black Anodize
4. Accessory :
 Push Pin : Plastic (UL94-V0)
 Thermal pad : T725 or others

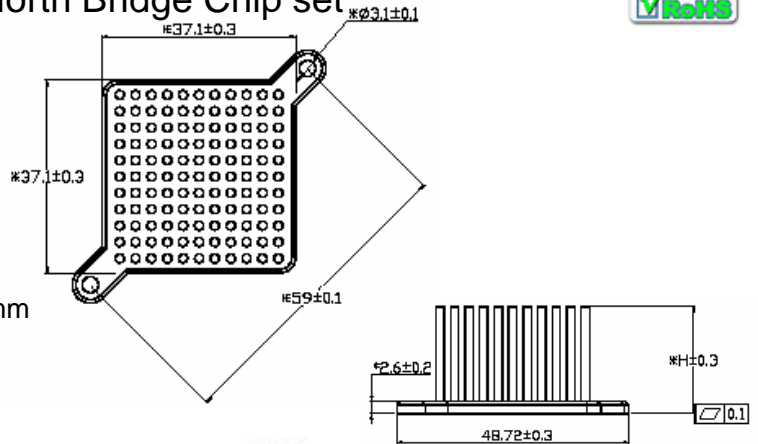

Performance

Heat Source (LxW)	15x15
-------------------	-------

